

Operation Manual of Outdoor High-Speed Pan/Tilt with Infrared Lighting

VER:2.20

Pleased read the manual carefully before using the product.

I. Notes for Attention

1. Read the manual carefully before installing the product.
2. There are two input ways of power supply: DC12V (vehicle) and AC24V (normal pan/tilt). Detailed connections refer to the description files.
3. There are sophisticated optical and electronic components inside the product. Avoid incorrect operation methods such as heavy pressing or strong vibration during the course of transportation, store and installation otherwise the product could be damaged.
4. Please do not dismount components inside the product to avoid occurrence of trouble. There is no part inside the product, which needs repair by customer himself.
5. Observe all electric safety standards in application and adopt special power supply attached the product. RS-485 control signal and video signal should be kept enough distance with the high voltage devices and cables during the course of transmission, and take protection measures such as anti-lightning and surging etc. if necessary.
6. Do not apply the product under the state exceeding limited temperature, humidity or specifications of power supply.
7. Do not aim the camera at the sun or very bright object, aim or monitor bright and still object for a long time whether the power supply of the camera is switched on or off.
8. Clean out dirt with special lens tissue if dust is stuck on the lens.

II. Description of Functions

This product is a high-tech monitor and controller which incorporates high definition color camera, universal variable pan/tilt, infrared lighting, multi-functional decoder, character superimposing, alarm input/output into a whole, reduces interconnections to a great extent among parts in the system and rises up the reliability of the system. In addition it has advantages of easy installation and maintenance, beautiful appearance, lightweight and flexible, simple operation etc.

1. Integrated Multi-Protocol Decoder

- a. The built-in decoder integrates 16 kinds of communication protocols in maximum. The baud rate of communication is adjustable. It has strong universality and is compatible with multiple common systems only by simple setting on the dip-switch.
- b. RS485 serial control: addresses of the pan/tilt 1 – 1023.

2. Integrated Panoramic Pan/Tilt

- a. To rotate continuously in unlimited 360° horizontally with speed from 0.9 – 60 rad/s and from - 85° – 90° vertically with manual speed of 40 rad/s.
- b. Smooth running at low speed with super lower noise. Images have no fluttering.
- c. Panoramic monitor without black spot and the positioning accuracy can reach $\pm 0.1^\circ$.

3. High Degree of Intelligence

- a. Preset memory has as much as 128 positions. Data are kept in memory even power is failure.
- b. Horizontal scan between two positions are supported. Scan speed can be altered and direction of pan can be selected freely. The pan/tilt can make scan larger or smaller than 180 °between any two positions with adjustable speed.
- c. Six groups of programmable patrol pattern are available with 16 preset positions each. The running speed and retained time for each preset position are adjustable respectively.
- d. Self-study function of pattern. The system can simulate the PTZ route of user's operation within 40

seconds and data are kept in memory even power is failure.

- e. Character superimposing function. It can display the address of the pan/tilt, title of the preset position etc.
- f. Long focus speed-limited function. The pan/tilt can adjust automatically the manual control speed depending on the focal length of the camera. The larger the magnification times, the slower the manual control speed thus to ensure searching the target rapidly and accurately.
- g. Integrated multiple protocols. A lot of communication protocols are integrated inside the pan/tilt with selectable baud rates from 2400 bps to 19200 bps.

4. Camera Function: Refer to Camera

- a. Control Mode of Focal Length: the user can manually adjust the focal length of the camera.
- b. Control of Magnification: the user can “pull up” or “push away” the lens
- c. Backlight Compensation: in case the lit object has dark background and couldn’t be displayed clearly, the user can switch on the backlight compensation .
- d. White Balance: in case images have distorted color on the screen, the user can set various kinds of modes by orders. There are six modes available for selection: ① indoor mode ② outdoor mode ③ trigger mode ④ auto tracking white balance ⑤ manual white balance ⑥ automatic mode.
- e. AE Mode: manual/automatic setup.
- f. Setup of Low Illumination: normally the camera operates under normal condition. In case when ambient illumination is lower than 1 LUX, the camera can automatically switch into zero illumination state . You can also make the camera under the zero illumination state manually.
- g. Other function: refer to different camera by using system menu to control.

5. Alarm Input/Output (only when used as normal pan/tilt, AC24V input)

- a. Four normal-open alarm inputs and close alarm.
- b. One group of the alarm output: normal-open and normal-close style.
- c. When the system identifies the alarm signal, it can start the pan/tilt and the camera immediately as per the setup of the program, and switch the image in the alarm zone into the main monitor, adjust the position of the alarm position, monitor the preset position and reflect conditions of the alarm zone as fast as it can.

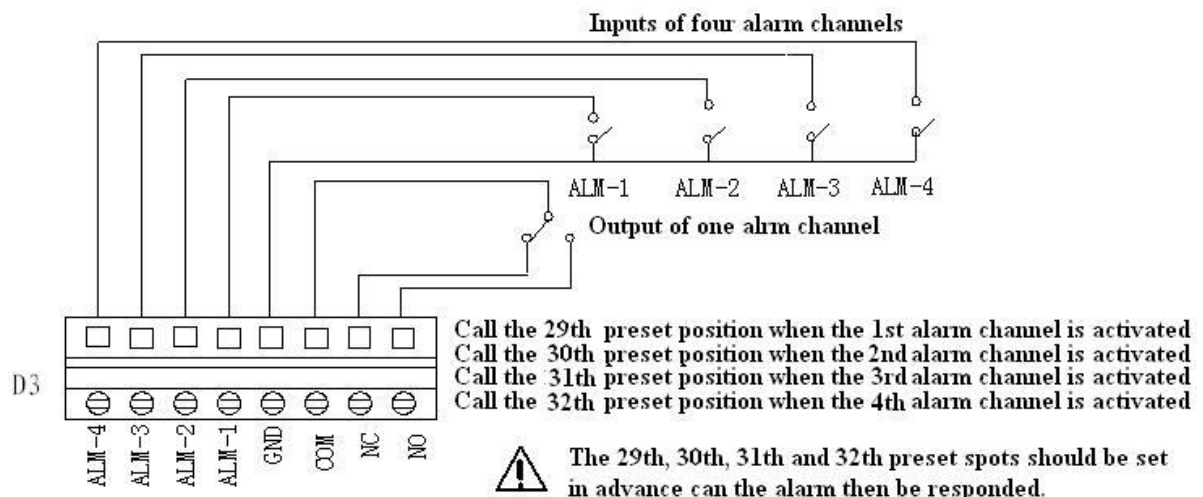

The alarm input should be the input signal with the switch type. Any other types of the input signal (such as voltage signal) could damage the dome camera. In case multiple channels have alarm signals, the pan/tilt shall response upon them on by one with the interval of 2 seconds. The pan/tilt shall do not response upon functions such as “pan”, “patrol” and “self-study” when the alarm signal in inputted.

6. Infrared System

- a. The infrared system is normally under automatic control state. The infrared lamp shall act followed by open/close of the low illumination of the camera;
- b. The open/close state of the infrared lamp can be changed by the menu manually;
- c. The default option on the menu of the infrared lamp is OFF. Normally the system detects external illumination and opens/closes the infrared lamp automatically. If the user changes the option of the infrared lamp into ON, the infrared system is changed into the manual control; if changing back into the automatic control, the user should set the option on the menu of the infrared at OFF.

III. Setup of the Menu of the Pan/Tilt

1. Basic Operation of the Menu

- 1.1 Open the main menu by the control keyboard or the matrix through the order “calling the 64th preset position” or the order “calling the 1st preset position” in two fast and consecutive times.
- 1.2 When the menu is displayed on the screen, operate “TILT UP”, “TILT DOWN” to move the cursor to the option to be set; and operate “PAN LEFT”, “PAN RIGHT” to modify contents or order to enter into the said option.
- 1.3 To speed up operation by making the joystick towards one direction for more than one second.
- 1.4 All setup on the menu could not be lost even the power is failed.
- 1.5 Special uses can be seen from the description of the menu.

2. Setup of the Menu

2.1 MAIN MENU

- 2.1.1 DISPLAY SETUP: To enter into the sub-menu of the display setup which can set the ID display, title display of the presser position and the display of the camera itself.
- 2.1.2 CAMERA SETUP: To enter into the sub-menu of the common data of the camera.
- 2.1.3 CONTROL SETUP: To enter into the sub-menu of the control data of the pan/tilt.
- 2.1.4 CAMERA MASK SET: To enter into the sub-menu of the control data of the camera mask.
- 2.1.5 PROGRAM: To enter into the sub-menu of the enhance function of the menu.
- 2.1.6 PAL CAMERA: To switch modes of PAL/NTSC, being identical with that of the camera.
- 2.1.7 CAM DEFAULT SET: To recover to the default setup of the camera.
- 2.1.8 RESET PT: To reset the system.
- 2.1.9 EXIT: To exit the main menu.

MAIN MENU	
1.	DISPLAY SETUP
2.	CAMERA SETUP
3.	CONTROL SETUP
4.	CAMERA MASK SET
5.	PROGRAM
6.	PAL CAMERA
7.	CAM DEFAULT SET
8.	RESET PT
9.	EXIT

2.2 DISPLAY SETUP

- 2.2.1 ID DISPLAY: when it is set at ON, the monitor shall display the address of the pan/tilt such as “CAM 001”. The default is ON when power supply is switched on.
- 2.2.2 ID POS: to set the display position of the pan/tilt, which can be at four corners of the screen such as TOP-L (upper left), TOP-R (upper right), BOTT-R (bottom left) and BOTT-L (bottom right).

DISPLAY SETUP	
1.	ID DISPLAY ON
2.	ID POS TOP-L
3.	TITLE DIS ON
4.	TITLE POS 01
5.	CAM DISPLAY ON
6.	RETURN

- 2.2.3 TITLE DIS: when it is set at ON, the title of the preset position can be displayed on the left side of the screen when calling the preset position, such as “NO.001 ABCDEFGH”. If no title of the position, then only “NO. 001” is displayed. The modification of the title of the preset position can be set at the PROGRAM option on the menu.
- 2.2.4 TITLE POS: To set the display position of the title of the preset position from the 1st line to the 10th line. The 1st line is at the top of the screen.
- 2.2.5 CAM DISPLAY: when it is set at ON, the display of the camera itself can be opened.
- 2.2.6 RETURN: To return to the main menu.

2.3 CAMERA SETUP

- 2.3.1 SLOW SHUTTER: frame accumulation function with options of manual/automatic. Under automatic state when the display of the camera is opened, ASS shall be displayed on the screen.
- 2.3.2 BACK LIGHT: backlight compensation open/close.
- 2.3.3 ICR SHOT: low illumination. ON – manual / AUTO – automatic.
- 2.3.4 IRIS: To set up automatic iris. AUTO – automatic / MANU – manual.
- 2.3.5 D-ZOOM: To set up digital zoom. ON – open / OFF – close.
- 2.3.6 FOCUS: To set up automatic focusing. AUTO – automatic / MANU – manual.
- 2.3.7 WB SET: ATW / INDOOR / OUTDOOR / ONEPUSH / AUTO / MANU.
- 2.3.8 MENU OF CAM: this option is empty.
- 2.3.9 RETURN: To return to the main menu.

CAMERA SETUP	
1.SLOWSHUTTER	AUTO
2.BACK LIGHT	OFF
3.ICR SHOT	AUTO
4.IRIS	AUTO
5.D-ZOOM	ON
6.FOCUS	AUTO
7.WB SET	ATW
8.MENU OF CAM	
9.RETURN	

2.4 CONTROL SETUP

- 2.4.1 ALARM: ON/OFF: Turn on or Turn off the alarm input function.
- 2.4.2 HOME OPTION: To enter into the sub-menu of automatic home function.
 - 2.4.2.1 AUTO HOME: When it is set at ON, the automatic home is opened. It means if the user has no any function in a period of time, the pan/tilt shall return home (HOME). The pan/tilt couldn't return home automatically if the pan/tilt is at patrol state. If no home returning is needed when the pan/tilt is under stop state, set this option at OFF.
 - 2.4.2.2 HOME POS: HOME is the returning position. If some scene is needed to set as HOME, call this scene on the camera and set it as the preset position 3, then call up the menu and enter into this sub-menu, and change the figure after HOME POS into 3. If you need to activate the automatic home, do not forget to set AUTO HOME at ON. HOME POS can be preset positions from 1 to 50.
 - 2.4.2.3 DWELL TIME: To set the time of automatic home, that is, if no control within the set time, it shall return home. The time can be from 1 to 99 minutes.
 - 2.4.2.4 RETURN: To return the menu one level upward.
- 2.4.3 IR_LED: The default option on the menu of the infrared lamp is

CONTROL SETUP	
1. ALARM	ON
2. HOME OPTION	
3. IR_LED	OFF
4. WIPER	OFF
5. WIPER MODE	
6. DEFOGGER	OFF
7. RETURN	

HOME OPTION	
1. AUTO HOME	ON
2. HOME POS	01
3. DWELL TIME	05 MIN
4. RETURN	

OFF. Normally the system detects external illumination and opens/closes the infrared lamp automatically. If the user changes the option of the infrared lamp into ON by the menu, the infrared system is changed

into the manual control; if changing back into the automatic control, the user should set the option on the menu of the infrared at OFF.

- 2.4.4 WIPER: WIPER open/close.
- 2.4.5 WIPER MODE: continuous or moment mode to be selected.
- 2.4.6 DEFOGGER: DEFOGGER open/close.
- 2.4.7 RETURN: To return to the main menu.

2.5 CAMERA MASK SET

- 2.5.1 MASK PRIVACY: ON/OFF
- 2.5.2 MASK SHADE: BLACK/GRAY/WHITE
- 2.5.3 MASK REGION: 6 or 2 privacy zone masking.(only for part of camera)
- 2.5.4 RETURN: return to Main Menu.

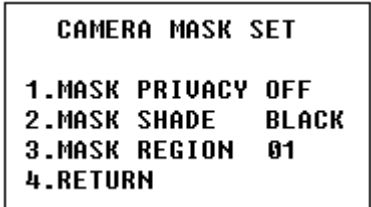

2.6 PROGRAM

- 2.6.1 AUTO PAN START POS: to set the start position of the pan between two positions. After entering you can move the dome camera by the joystick. Push CLOSE button you can store current position and return.
- 2.6.2 AUTO PAN END POS: to set the end position of the patrol between two positions. After entering you can move the pan/tilt by the joystick. Push CLOSE button you can store current position and return.
- 2.6.3 RUN AUTO PAN: to pan between two positions. Please set the start position and the end position of the pan first. If the start position is just the end position, the dome camera shall make 360° pan. The speed of the pan is divided into six grades: FAST / NORMAL / SLOW / -FAST / -NORMAL / -SLOW. The first three grades are the pan less than 180° while the rear three grades are the pan larger than 180°. Adjust speed by PAN LEFT/PAN RIGHT and press OPEN button to exit the menu. The start position and the end position of the pan can be set up by options 1 and 2 of the menu.
- 2.6.4 SET TITLE: to edit the title of the preset position. Only **first 63 positions** can have their titles. Select the number of the preset positions by PAN LEFT/PAN RIGHT and press OPEN button to enter into the edit state. Operations under the edit state are shown below.
- 2.6.5 SET PATROL: to edit patrol data of multiple positions. Select the number of the pattern by PAN LEFT/PAN RIGHT and press OPEN button to enter into the edit state. Operations under the edit state are shown below.
- 2.6.6 RUN PATROL: To run patrol of multiple positions. Select the number of the pattern by PAN LEFT/PAN RIGHT and press OPEN button to exit the menu.
- 2.6.7 RECORD PATTERN: To edit self-study of patrol. It can remember PTZ operation in 40 seconds in maximum. When the 40th second is up or press CLOSE button, the edit is terminated.
- 2.6.8 RUN PATTERN: To run self-study pattern. After running it shall exit the menu. Control the joystick to terminate its running.
- 2.6.9 RETURN: To return to the main menu.



3. Appendix to the Menu

Operation of Multiple Patrol Positions under Edit State. After entering into Edit state, operations on the

screen are as follows:

The prompt messages are displayed on both top and bottom lines and information of every pattern is displayed in the middle of the screen. **One line includes data of two patrol positions.** Move the cursor by PAN LEFT/RIGHT and change values by TILT UP/DOWN. Press down buttons for more than one second to speed up operation. Press CLOSE button to exit the Edit state and store the revisions. The program can search the first position where POS is “---”, and store data in front of it and regard data after it ineffective. Look the above drawing for example, the program stores first four patrol positions. The settable range of POS is from 1 to 63 and 65 to 128. When POS is “---“, it means the range of the patrol is finished. The settable range of SP is from 0 to 8 (0 is the same with 1 and has the fastest speed while 8 has the lowest speed). The settable range of TM is from 0 to 99 seconds.

NO	POS	SP	TM	POS	SP	TM
01	001	01	01	002	01	01
03	003	01	01	004	01	01
05	---	---	---	---	---	---
07	---	---	---	---	---	---
09	---	---	---	---	---	---
11	---	---	---	---	---	---
13	---	---	---	---	---	---
15	---	---	---	---	---	---
SEQ:01		CLOSE:EXIT				

NO - No. of Patrol Position
 POS - No. of Preset Position
 SP - Leaving Speed
 TM - Dwell Time

After entering into Edit state, following information displays on the screen:
EDIT AREA: one line includes data of two patrol positions.

SEQ:01 - It means current set sequence is 1
 CLOSE:EXIT - Press CLOSE to exit Edit state

Operation of Title of Preset Position under Edit State. After entering into Edit state, the display on the screen is shown as follows: from the drawing we can find the current setup is the first preset position with the title of “NO TITLE”. Move the cursor by PAN LEFT/RIGHT and change values by TILT UP/DOWN. Press down buttons for more than one second to speed up operation. Press CLOSE button to exit the Edit state and store the revisions. The title of the preset position can include 8 characters in maximum such as 0-9, A-Z, +, - and blank. Note: the first letter should be 0-9 or A-Z, otherwise it means the title of the preset position should be deleted. When calling the preset position, it only displays “NO.XXX” without the title.

PRESET NO:01
TITLE: NO TITLE
CLOSE:EXIT

IV. Setup of the Intelligence Full-Dome Pan/Tilt

Before installing the product, first of all confirm the communication protocol and the baud rate of the main machine in the system, then set the dip-switch SW2 of the pan/tilt to be identical with that of the system, set the address of the pan/tilt on SW1 and the type of the communication protocol and the baud rate on SW2.



(Figure 1)

1. Terminal Resistor:

The jumper JP1 is the option switch of 120 Ω terminal resistor of the bus RS485. When it is at 2—3 state, 120

Ω terminal resistor is opened and no bus 485 is connected; when it is at 1—2 state, 120 Ω terminal resistor is connected in parallel with the bus 485. In the bus RS485 system, there is only one pan/tilt, which has the terminal resistor to be connected in the circuit and other pan/tilts whose terminal resistors are opened so as to increase the reliability of the system. Generally, the terminal resistor of the pan/tilt at the farthest end from the control circuit is connected and all terminal resistors of other devices are opened.

2. Power Supply Panel for the Vehicle Pan/Tilt:

- a. Input voltage is DC10.5-18V, $I_{in} \geq 3.5A$;
- b. No alarm input and output.

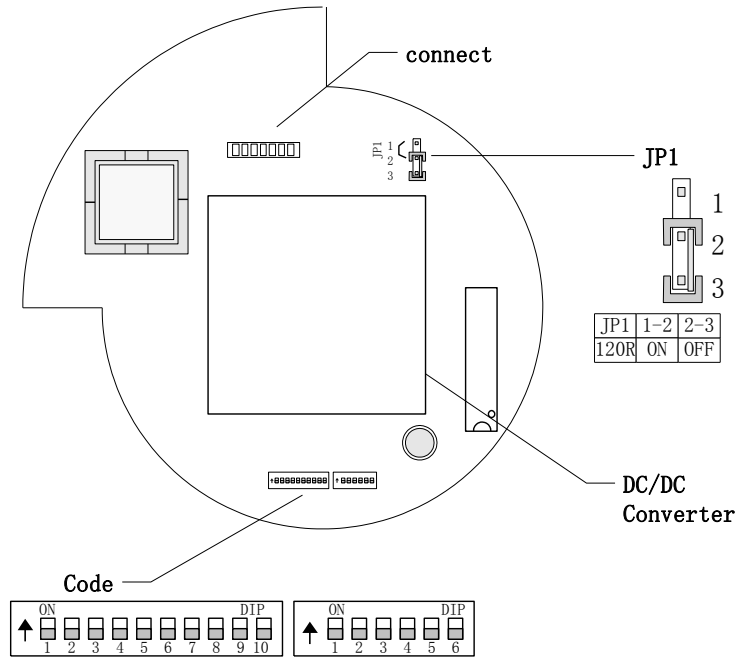

3. Power Supply Panel for the Vehicle Pan/Tilt: :

- a. Input voltage is AC24V, $I_{in} \geq 2.5A$;
- b. With alarm input and output;
- c. External synchronization.

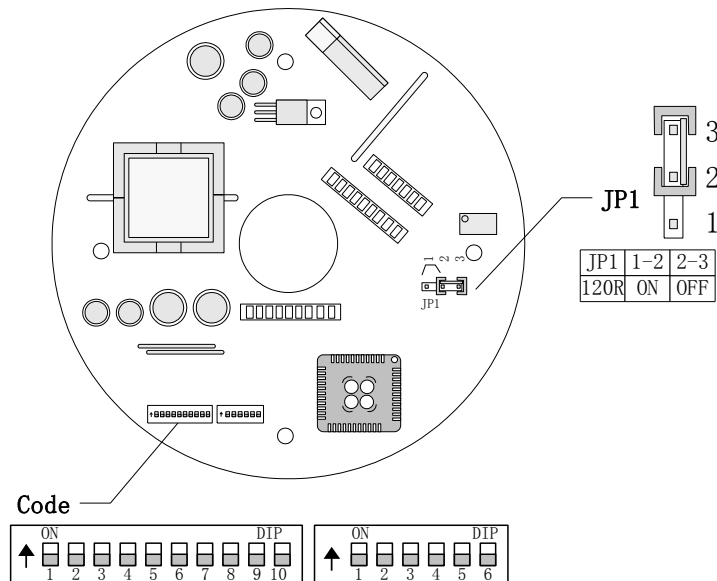

The jumper JP1 is the option switch of 120 Ω terminal resistor of the bus RS485.

4. Dip-Switch of Address:

Dome Address	States of Dip-Switch									
	DIP-1	DIP-2	DIP-3	DIP-4	DIP-5	DIP-6	DIP-7	DIP-8	DIP-9	DIP-10
1	ON	OFF	OFF	OFF	OFF	OFF	OFF	OFF	OFF	OFF
2	OFF	ON	OFF	OFF	OFF	OFF	OFF	OFF	OFF	OFF
3	ON	ON	OFF	OFF	OFF	OFF	OFF	OFF	OFF	OFF
4	OFF	OFF	ON	OFF	OFF	OFF	OFF	OFF	OFF	OFF
5	ON	OFF	ON	OFF	OFF	OFF	OFF	OFF	OFF	OFF
6	OFF	ON	ON	OFF	OFF	OFF	OFF	OFF	OFF	OFF
7	ON	ON	ON	OFF	OFF	OFF	OFF	OFF	OFF	OFF
8	OFF	OFF	OFF	ON	OFF	OFF	OFF	OFF	OFF	OFF
9	ON	OFF	OFF	ON	OFF	OFF	OFF	OFF	OFF	OFF
10	OFF	ON	OFF	ON	OFF	OFF	OFF	OFF	OFF	OFF
11	ON	ON	OFF	ON	OFF	OFF	OFF	OFF	OFF	OFF
12	OFF	OFF	ON	ON	OFF	OFF	OFF	OFF	OFF	OFF
13	ON	OFF	ON	ON	OFF	OFF	OFF	OFF	OFF	OFF
14	OFF	ON	ON	ON	OFF	OFF	OFF	OFF	OFF	OFF
15	ON	ON	ON	ON	OFF	OFF	OFF	OFF	OFF	OFF
16	OFF	OFF	OFF	OFF	ON	OFF	OFF	OFF	OFF	OFF
17	ON	OFF	OFF	OFF	ON	OFF	OFF	OFF	OFF	OFF
18	OFF	ON	OFF	OFF	ON	OFF	OFF	OFF	OFF	OFF
...	...									
1023	ON	ON	ON	ON	ON	ON	ON	ON	ON	ON

SW1 is used to set the addresses of the pan/tilt which has the range from 1 to 1023. From DIP-10 to DIP-1 it corresponds to a binary number with 10 bits in which the highest bit is DIP-10 and the lowest bit is DIP-1. The state ON for each bit means 1 while the state OFF means 0. The encodes of some addresses are as follows:
For example:

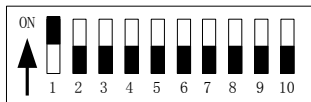

Speed Dome Address=1

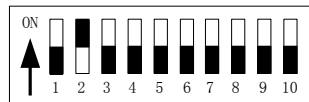

Speed Dome Address=2

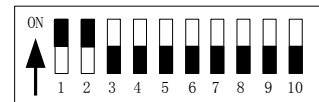

Speed Dome Address=3

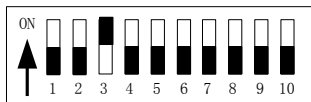

Speed Dome Address=4

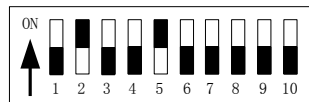

Speed Dome Address=18

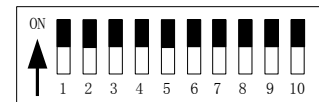

Speed Dome Address=1023

- The address of the dome camera is set according to the binary coding system in which ON means “1” and OFF means “0”.
- The coded addresses shown above are only from 1 to 18 and those from 19 to 1023 are and so forth.
- Setup of the protocol: the protocol is set up by the first four bits of SW2 and the baud rate is set up by the later two bits. Please refer to the following table and set the protocol and the baud rate to be identical with that of the main machine.

5. Selection of the Protocol and the Default Baud Rate:

SW2 is used to set the communication protocol and the baud rate used by the pan/tilt. Bits from DIP-4 to DIP-1 of the SW2 are used to select the protocol and 16 different protocols can be selected in maximum. The encoded table of the protocol selected by the pan/tilt is as follows:

Type or Protocol	Selection of Communication Protocol				Normal Baud Rate	
	DIP-1	DIP-2	DIP-3	DIP-4	DIP-5	DIP-6
SAMSUNG	ON	OFF	OFF	OFF	OFF	ON
B01	ON	OFF	OFF	OFF	OFF	ON
NEON	ON	OFF	OFF	OFF	OFF	ON
Santachi	OFF	ON	OFF	OFF	OFF	ON
PELCO-D	ON	ON	OFF	OFF	OFF	OFF
PELCO-P/4800	OFF	OFF	ON	OFF	ON	OFF
PELCO-P/9600					OFF	ON
PANASONIC	ON	OFF	ON	OFF	OFF	ON
Longcomity	OFF	ON	ON	OFF	OFF	ON
HUNDA600	ON	ON	ON	OFF	OFF	ON
LILIN	OFF	OFF	OFF	ON	OFF	ON
VICON	ON	OFF	OFF	ON	ON	OFF
MOLYNX	OFF	ON	OFF	ON	OFF	ON
KALATEL	ON	ON	OFF	ON	ON	OFF
VCL	OFF	OFF	ON	ON	OFF	ON
Reserved	ON	OFF	ON	ON	OFF	ON
ALEC	OFF	ON	ON	ON	OFF	ON
Ultrak	ON	ON	ON	ON	OFF	ON

6. Setup of the Baud Rate of Communication of the Pan/Tilt (later 2 bits of SW2)

Position of Dip-Switch Baud Rate of Communication	1	2	3	4	5	6
	2400 bps					OFF
4800 bps					ON	OFF
9600 bps					OFF	ON
19200 bps					ON	ON

7. Schematic Drawing of Dip-Switch for Reference:

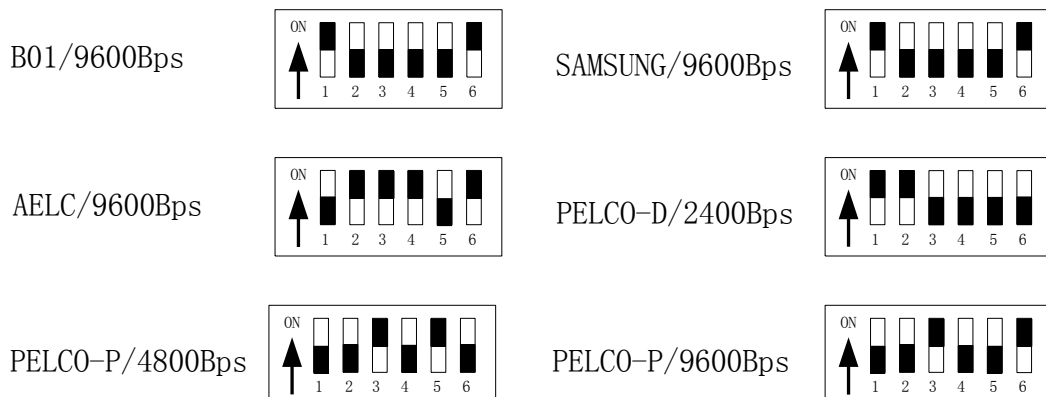

8. Description of the Terminals

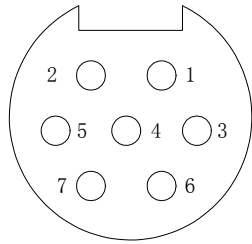

A. 7-Core Input Terminal

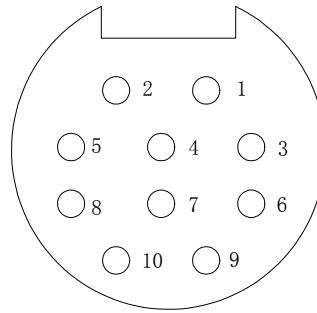

B. 10-Core Input Terminal

8.1 Description of 7-Core Terminal:

1. DC12V(AC24V): red	2. GND(AC24V): black
5. R+ (communication+): orange	3. R- (communication-): yellow
6. V+: (VF+)	4. Null
7. V-: (VF-)	

8.2 Description of 10-Core Terminal:

1. Alarm-1 in: red	2. Alarm-2 in: orange
3. Alarm-3 In: yellow	4. Alarm-4 In: green
6. Alarm In COM: black	7. Alarm Out COM: white
9. Alarm NO out: blue	10. Alarm NC COM: pink
	5. NC
	8. NC

8.3 Description of 10-Core Socket:

- a. When 7-core input takes DC voltage, 10-core socket is free and there is no alarm system;
- b. When 7-core system takes AC 24V voltage, 10-core socket is used for the alarm system.

V. Installation of the Product

5.1 Drawing of the Sizes of the Product

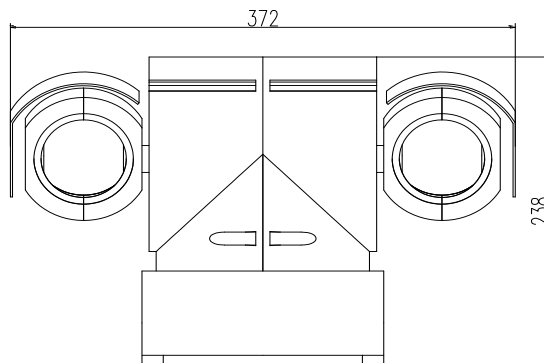

Outline Sizes of the Pan/Tilt

5.2 Installation Style of the Product

A. Installation Style of Plain Base

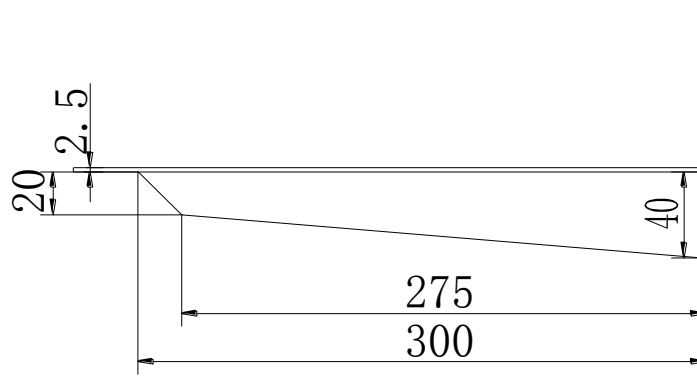

Drawing of Sizes of the Side

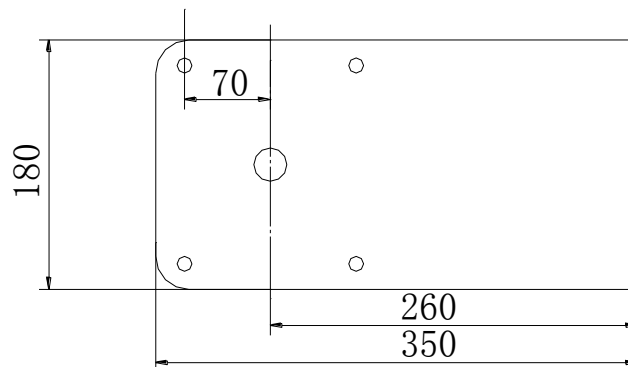

Drawing of Sizes of the Bottom

B. Vehicle -Carried

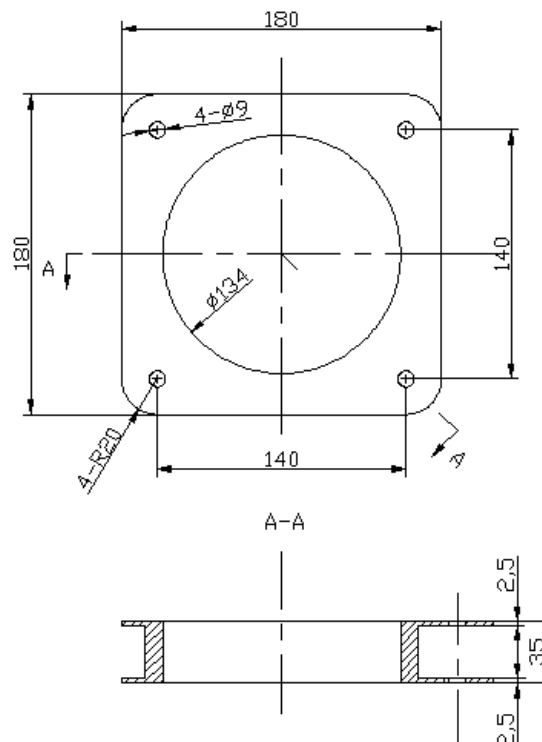

Sizes of the Shock Absorber

5.3 Installation Procedures of the Product

1. Remove the bottom plate of the pan/tilt;
2. Set the corresponding information in accordance with the schematic drawing of the dip-switch of addresses, protocols and baud rates;

3. Install the bottom plate of the pan/tilt and take care of the tightness of waterproof seal ring;
4. If vehicle-carried pan/tilt is used, first of all fix the chock absorber on the bottom of the pan/tilt then fix the whole pan/tilt;

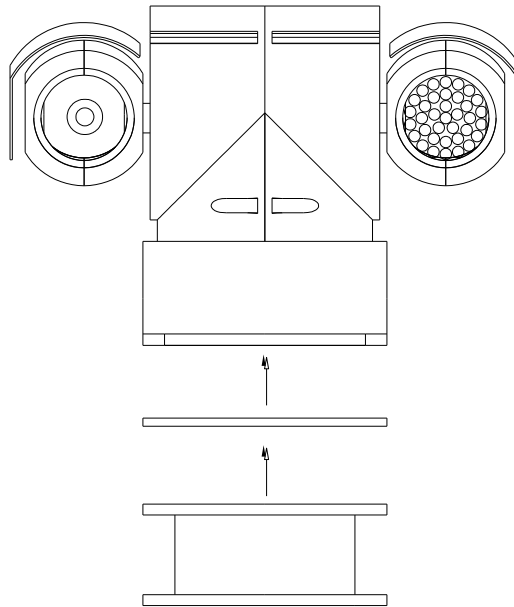

5. If the plain base is used, fix the pan/tilt onto the fixation hole of the pan/tilt;
6. Connect the output wires of the socket according to relative colors on the schematic drawing and do not make wrong connections.

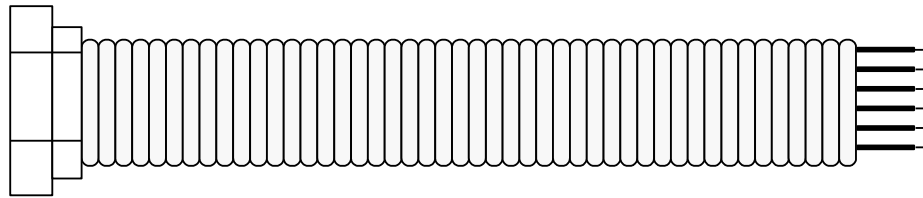

Attention: refer to power label

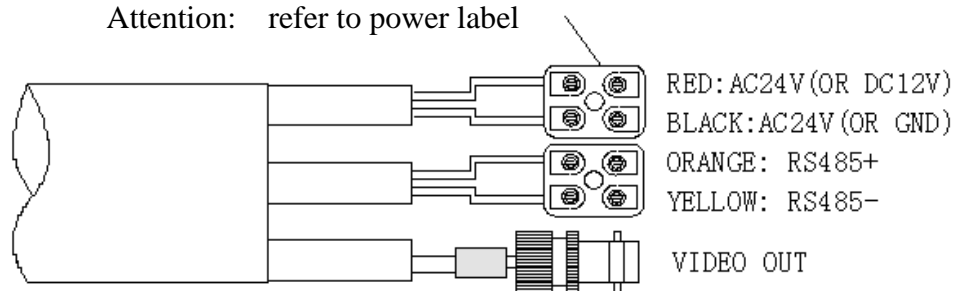

Attention: the input of power supply couldn't be selected and should be connected as per actual applied style. The vehicle-carried pan/tilt takes DC power supply while common pan/tilt takes AC power supply.

7. For the common pan/tilt, 10-core socket is used as the alarm interface and detailed connection can be seen from the description of colors of terminals.

VI. Connection Drawing of the System for Reference

6.1 Schematic Drawing of Common Pan/tilt:

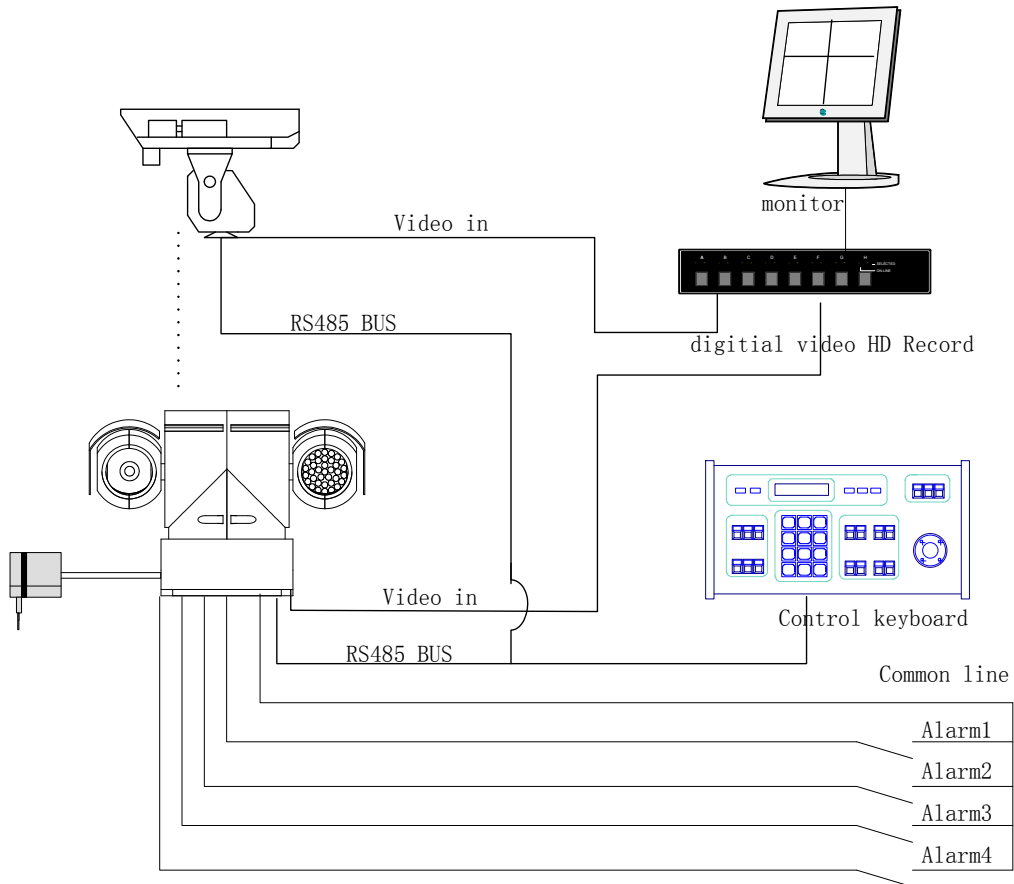

6.2 Schematic Drawing of the Vehicle-Carried Pan/Tilt (the shock absorber is added):

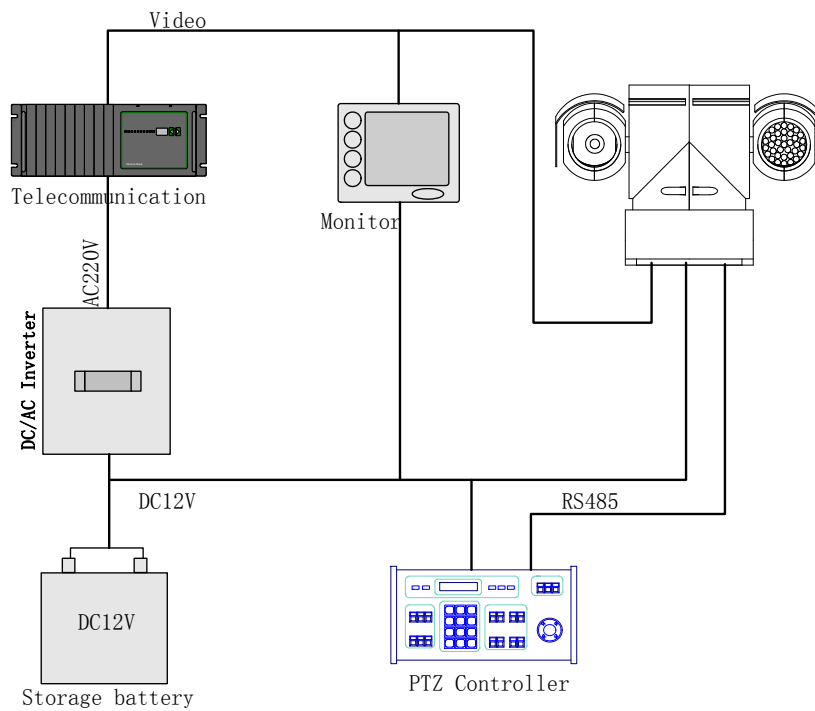

VII. Main Technical Index

Specifications	Power Supply (Option)	DC12V $I_{in} \geq 3.5A$		
		AC24V $\pm 10\%$ $I_{in} \geq 2.5A$		
	Power Consumption	30VA		
	Weight	10Kg		
	Installation Style	Plain Base Installation/Vehicle-Carried		
	Relative Humidity	10-90%		
	Operation Temperature	-35°C ~ 55°C		
Waterproof Class	IP66			
Camera Functions	Model	18x	23x	27x
	Image Inductor	1/4" color CCD		
	Effective Pixels	752H \times 582V		795H \times 596V
	Synchronization System	Inside		
	Video Output	Compound Signal 1.0Vp-p/75 Ω		
	White balance	Automatic/Manual		
	Scan System	15.625KHz(H) 50Hz(V)		
	Horizontal Resolution	480TVL		
	Signal/Noise Ratio	≥ 50 db		≥ 48 db
	Electronic Shutter	1/3 ~ 1/10000 sec		1/50 ~ 1/10000 sec
	Lowest LUX	0.01 ~ 1 Lux		
	focusing Range	f=4.1~73.8mm 18x	f=3.6~82.8mm 23x	f=3.6~98mm 27x
Iris & Zoom	Automatic/Manual			
Basic Functions of Pam/Tilt	Pan Movement	70 %s max		
	Tilt Movement	60 %s max		
	Preset Position	128 positions in maximum		
	Patrol Function	6 patrol patterns are stored in maximum		
	Scanning Speed	0.5 ~ 30 %s		
	Self-Study Pattern	40 sec		
Infrared Lamp	Infrared Illuminator	High Brightness LED \times 36pcs		
	Wavelength	850 nm		
	Project Distance	120 m		
	Power Consumption	4 W		
	Control of Infrared Lamp	Auto/Manual control on menu		
	Service Life of Infrared Lamp	Over 20000 hours		
Alarm	Four Channel Inputs	Normal Open, closing for alarm		
	One Channel Output	Normal Open, Normal Close Output		

VIII. Normal Troubles and Remedies

Troubles	Possible Causes	Remedies
No action and images after switching on	Power supply damaged of insufficient electric power	Replace
	Wrong connection of power supply wires	Make correction
	Engineering circuits failed	Remove
Abnormal self-inspection, images with humming of motor	Mechanic trouble	Repair
	Pan/tilt may be inclining	Re-fix
	Insufficient electric power	Replace with qualified power supply
Normal self-inspection, no images	Wrong connection of VF circuit	Make correction
	Bad contact of VF circuit	Remove
	Camera damaged	Replace
Successful self-inspection without control	Wrong connection of control signal wires	Make correction
	Mismatched address	Re-select
	Mismatched protocol	Make mismatch of protocol and controller and restart
Unstable images	Bad contact of VF circuit	Remove
	Insufficient electric power	Replace
Dome pan/tilt out of control	Abnormal self-inspection	Restart
	Bad contact of control circuit	Remove
	Operation of main machine has problem	Restart the main machine
	Much load or communication distance too far	1. Connect 120Ω resistor of the farthest dome pan/tilt from the controller and disconnect all other resistors; 2. Add coding divider
Auto/Manual of infrared lamp ineffective	Infrared lamp may be damaged	Rework

Some common troubles and their causes and remedies are listed above for your reference. Should you meet other special problem, you can contact with the dealer directly for technical support.